

South Bend

THE BEST IN RODS • REELS • LINES • LURES

REEL REPAIR BULLETIN #4-1

Sup-matic

606-G 707-G

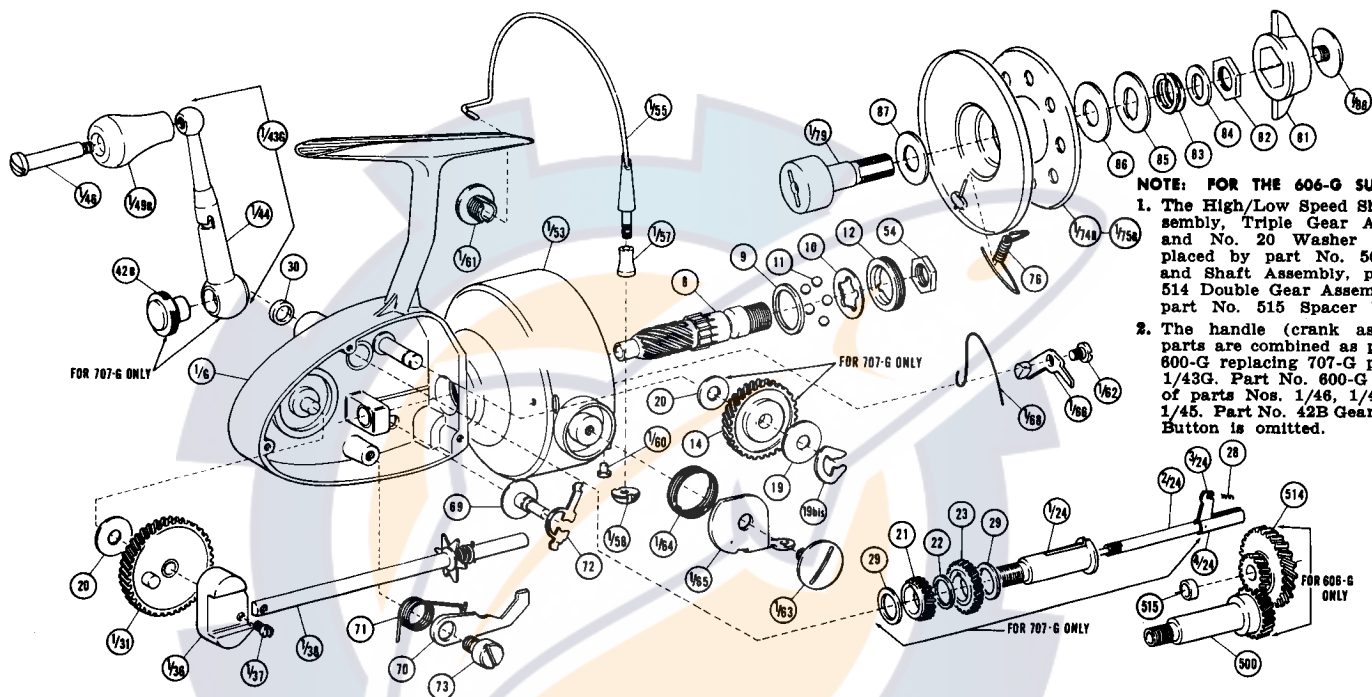

NOTE: FOR THE 606-G SUP-MATIC

1. The High/Low Speed Shaft Assembly, Triple Gear Assembly and No. 20 Washer are replaced by part No. 500 Gear and Shaft Assembly, part No. 514 Double Gear Assembly and part No. 515 Spacer Washer.
2. The handle (crank assembly) parts are combined as part No. 600-G replacing 707-G part No. 1/43G. Part No. 600-G consists of parts Nos. 1/46, 1/49B and 1/45. Part No. 42B Gear Change Button is omitted.

PART NO.	NAME	PRICE	PART NO.	NAME	PRICE	PART NO.	NAME	PRICE	PART NO.	NAME	PRICE
1G	Housing	\$4.25	29	Gear Change Shaft Adjusting Shims	\$.10	1/61	Pick-up Bail Button	\$.20	82	Drag Compression Nut	\$.10
7	Cover Screw	.10	30	Driving Shaft Bushing	.10	1/62	Trip Lever Screw	.10	83	Drag Spring	.15
8	Worm Gear	1.25	1/31	Smooth Wind Gear	.75	1/63	Bail Plate Screw	.25	84	Upper Washer	.10
9	Cover Ring	.35	1/36	Roller Slide	.35	1/64	Bail Spring	.10	85	Lower Washer	.10
10	Ball Plate Guide	.10	1/37	Slide Screw	.10	1/65	Bail Holder	.35	86	Upper Fiber Friction Washer	.10
11	Ball Bearings	.10	1/38	Main Shaft Assembly	.75	1/66	Bail Trip Lever	.10	87	Lower Fiber Friction Washer	.10
12	Upper Threaded Ring	.60	42B	Gear Change Button — 707-G ONLY	.20	1/68	Bail Trigger Spring	.10	1/88	Wing Nut Retaining Screw	.35
14	Triple Gear Assembly — 707-G ONLY	1.20	1/43G	Handle Complete — 707-G ONLY	1.90	69	Anti-reverse Button	.65	1/74A-B	Large Capacity Spool — Assembled	3.00
19	Washer	.10	1/44	Handle Arm — 707-G ONLY	1.60	70	Anti-reverse Dog	.10	1/75A-B	Small Capacity Spool — Assembled	3.00
19 bis	Circlip	.10	1/46	Handle Knob Shaft	.10	71	Anti-reverse Dog Spring	.10	FOR 606-G REEL ONLY		
20 THRU 29 FOR 707-G REEL ONLY			1/53	Drum	2.75	72	Anti-reverse Retaining Spring	.10	500	Gear and Shaft Assembly	\$2.00
20	Washer	\$.10	1/49B	Handle Knob	.20	73	Anti-reverse Dog Spring	.10	514	Double Gear Assembly	1.00
21	Low Speed Gear	.40	54	Lock Nut	.10	74B	Spool, Large Capacity	.75	515	Spacer Washer	.15
22	Gear Shift Washer	.15	1/55	Pick-up Bail Assembly	1.25	1/75B	Spool, Small Capacity	.75	1/45	Handle Arm (not shown)	1.20
23	High Speed Gear	.45	1/57	Pick-up Roller	.20	76	Drag Spring	.10	600-G	Handle (Crank Assembly)	1.50
1/24	High Speed Shaft	1.15	1/58	Roller Lock Nut	.10	78	Drag Click Screw	.10			
2/24	Low Speed Shaft	.75	1/60	Shock Absorber	.10	1/79	Spool Shaft	.50			
3/24	Gear Pawl	.35									
4/24	Gear Pawl Pin	.10									
28	Gear Change Spring	.10									

DISASSEMBLY and ASSEMBLY INSTRUCTIONS

1. Hold the reel with the crank handle 1/49 pointing at you. Turn the whole handle assembly clockwise and unscrew it.
 2. Remove spool 1/74 or 1/75 by pressing the spool inward and then turning it in any direction about 45° to free it.
 3. Turn the reel 90° and unscrew cover screw 7. Remove the plate and the housing is open for washing, oiling and greasing.
 4. Unscrew slide retaining screw 1/37 and you can remove the main shaft 1/38, roller slide 1/36 and smooth wind gear 1/31. Do not drop brass bearing washer 20.
 5. By pushing the Circlip 19 bis sideways out from the shaft groove, you can disassemble the intermediate gear and also the crank shaft and gear assembly 24.
 6. Reverse procedure to assemble.
- NOTE:** Gear Change Button No. 42B must be slightly heated before unscrewing.

NOTE: When ordering parts, give reel part name, reel number and model.